

Product Group MFSR

Machine feet made of zinc-plated steel with fixing system and vulcanised rubber base

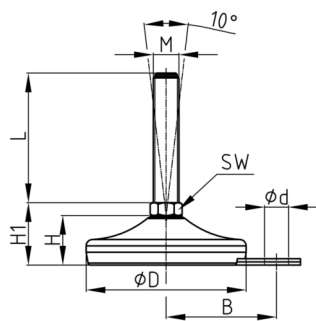

Material

- Base body: zinc-plated steel
- Rubber: NBR 80 Shore, vulcanized

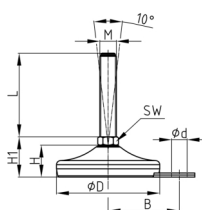

Product information

- The machine foot is a combination of balancing function and vibration damping.
- The foot consists of a metal plate that has been pressed into a mould. The vibration-damping rubber is vulcanised into the resulting recess.
- The machine foot can compensate for uneven floors up to 10°.
- The load capacity of the screw (buckling length!) may be less than indicated in the table.

B	D	d	F max.	H	H1	M	WAF	50	75	100	150	200	250
mm	mm	mm	kg	mm	mm		mm	mm	mm	mm	mm	mm	mm
54	80	15	1000	25	35	M10	14	x		x			
54	80	15	1000	25	35	M12	14	x		x	x		
54	80	15	1000	25	35	M14	14	x		x	x		
54	80	15	1000	25	35	M16	16		x	x	x		
54	80	15	1000	25	36	M20	20		x	x	x	x	
54	80	15	1000	25	36	M24	24		x	x	x	x	
69	100	15	1500	28	37,5	M16	16		x	x	x	x	
69	100	15	1500	28	38,5	M20	20		x	x	x	x	x
69	100	15	1500	28	38,5	M24	24			x	x	x	x
69	100	15	1500	28	39,5	M30	30			x	x	x	x

Ordering example

- Group + D + M + Thread Length ----> MFSR 80 M10x 50